

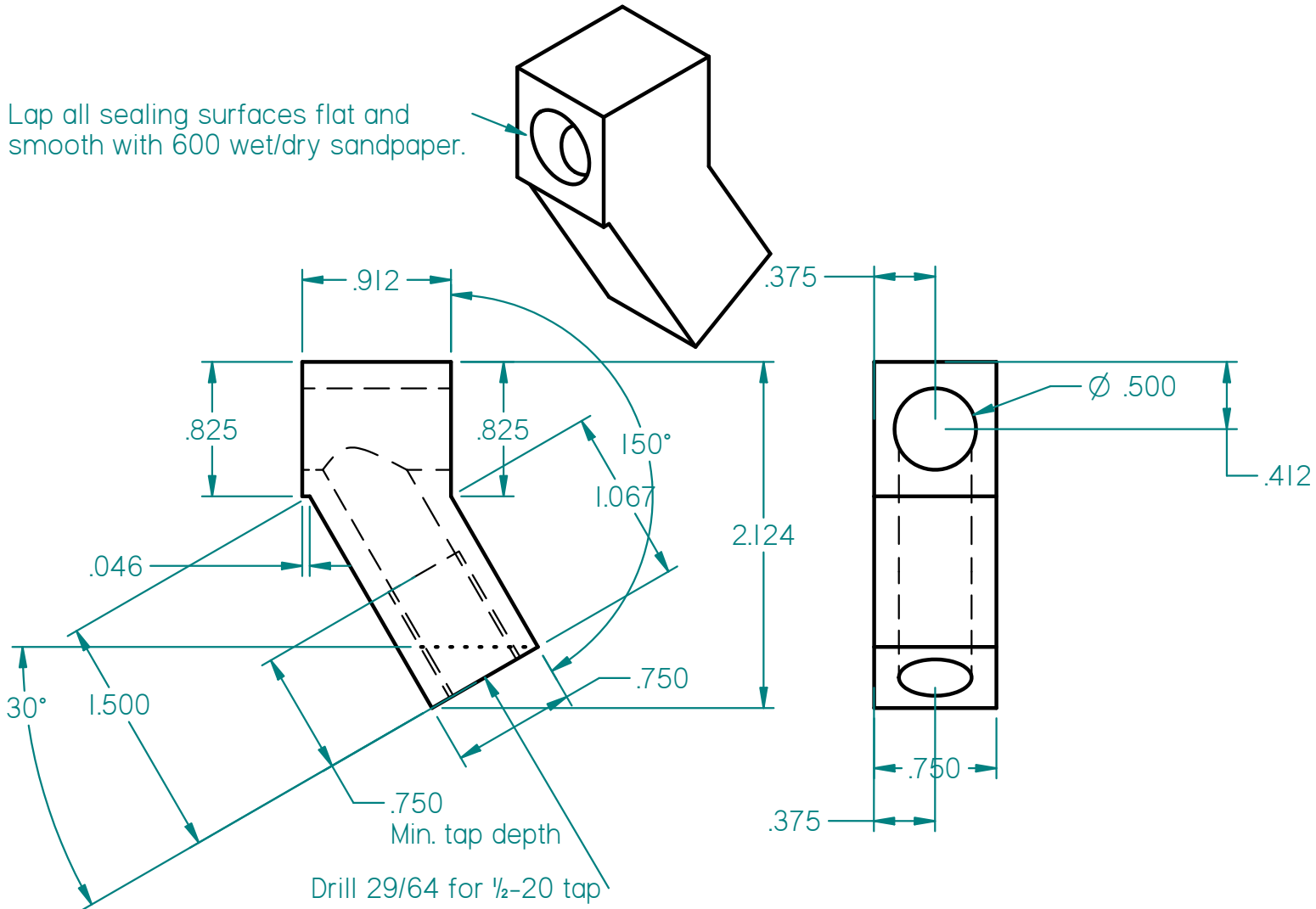

Lap all sealing surfaces flat and smooth with 600 wet/dry sandpaper.



Material: any machinable aluminum:
6061-T651, 7075, 2024, etc.

Mark with maker's name and date
Corrosion proof with anodize or alodine

	NAME	DATE	 <small>YOUR HOMEBUILT AIRCRAFT AUTHORITY</small>	
DRAWN	Bob	04/25/20		
CHECKED			TITLE Adapter Billet, Curtis Drain Valve	
ENG APPR				
MGR APPR			SIZE A DWG NO 4-25-2020BHD2 REV	
UNLESS OTHERWISE SPECIFIED DIMENSIONS ARE IN INCHES ANGLES ±XX° 2 PL ±X.XX 3 PL ±X.XXX			FILE NAME: valve adapter one piece.dft	
			SCALE:	WEIGHT: